

## Installation instructions for Nelson-Rigg® Touring Series GWS-450, 500 Seat Pack

Read instructions carefully before installation. If you have any questions or something is unclear, please contact us or your dealer for clarification. Make sure your motorcycle is clean and free from dirt, road grime etc. where the Nelson-Rigg® luggage mounts.

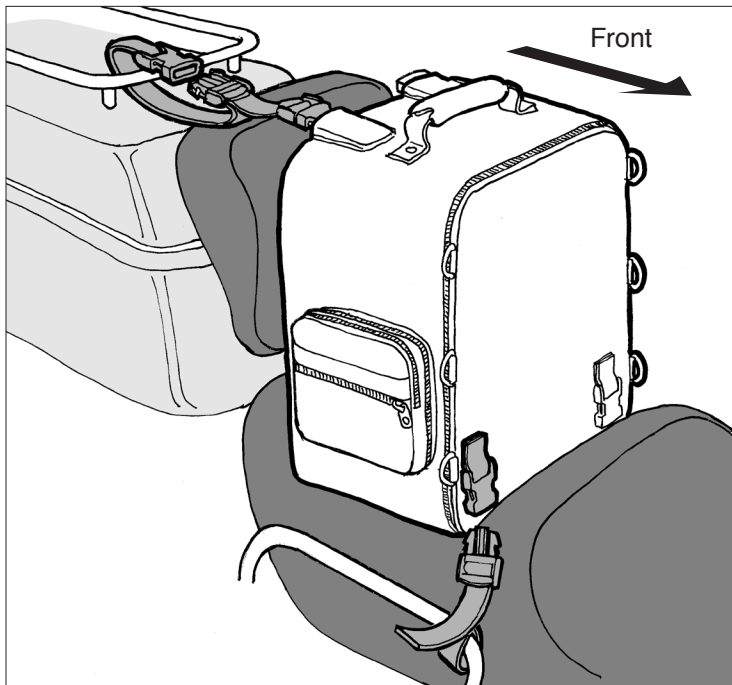

Rear Seat Pack is designed to be used when no passenger is carried. Place bag on the passenger seat with the logo facing forwards. Fasten the male buckle straps around the passenger grab rail or some other solid part of the motorcycle. Snap buckles into the front female buckles at the base of the bag. Cinch down straps.

Using 2 of the supplies straps with 2 male and one female buckle, secure around luggage rack on top box by passing the female buckle around one of the tubes of the rack and clipping it into the male buckle as shown. Snap remaining male buckle into female buckles on top of bag and cinch down.

### Alternate mounting option for Honda® GL-1500 & 1800 with or w/o luggage rack

For the Honda® GL-1500 or 1800 with or without a luggage rack, another mounting option would be installing one end of the hold-down strap inside the top trunk. Open top trunk lid. Notice

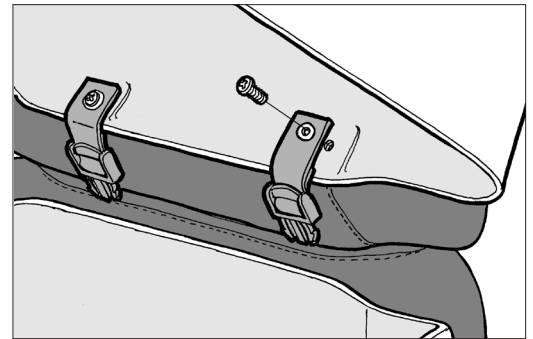

the 2 small factory Phillips head screws in the compartment at the front of the lid. Remove one screw at a time. Using these screws, place them through the brass eyelets in the straps with the male buckles at one end. Hand tighten the screws. (Do not use excessive force or an electric or air powered screw gun). Take the long strap with the male buckle on one end and female buckle on the other (sliding male buckle will not be used for this mounting option) and connect the female buckle to one of the short straps with the brass eyelets (now screwed into trunk). Route the long strap underneath of the trunk lid, between the backrest on the lid and the back of the seat. You should now be able to see the male buckle on the passenger seat when the rear trunk lid is closed.

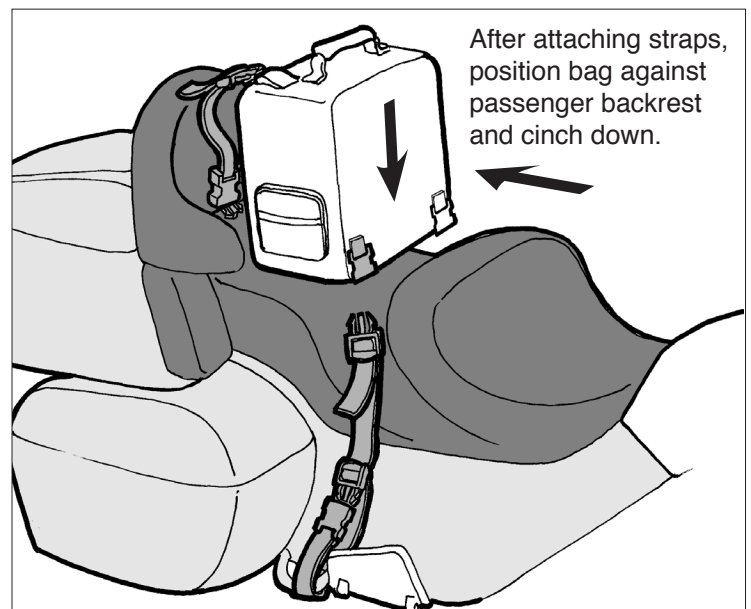

#### Warning:

Read the installation instructions and make yourself familiar with the process of installing the Nelson-Rigg® product(s) on your bike. It is your responsibility to mount the product correctly and securely as outlined in these instructions. Nelson-Rigg® products are intended for use at USA street legal speeds as posted by the individual States. Nelson-Rigg® luggage must not be overloaded. Max carrying capacity is 10 lbs per bag or the maximum load suggested by the manufacturer of the vehicle, whichever is less.

Failure to adhere to these warnings may result in, but not be limited to: the luggage becoming detached, the product becoming tangled in moving parts of the vehicle, unstable vehicle dynamics, reduction in the ability to control the vehicle. The result(s) could lead to serious injury.

**Always ride safely, adhering to the local highway regulations. Always wear a helmet and protective apparel.**

[www.nelsonrigg.com](http://www.nelsonrigg.com)

it's not just a bike®

**NELSON-RIGG**