

Installation instructions for Nelson-Rigg® Touring Series GWR-950, 1000

Read instructions carefully before installation. If you have any questions or something is unclear, please contact us or your dealer for clarification. Make sure your motorcycle is clean and free from dirt, road grime etc. where the Nelson-Rigg® luggage mounts.

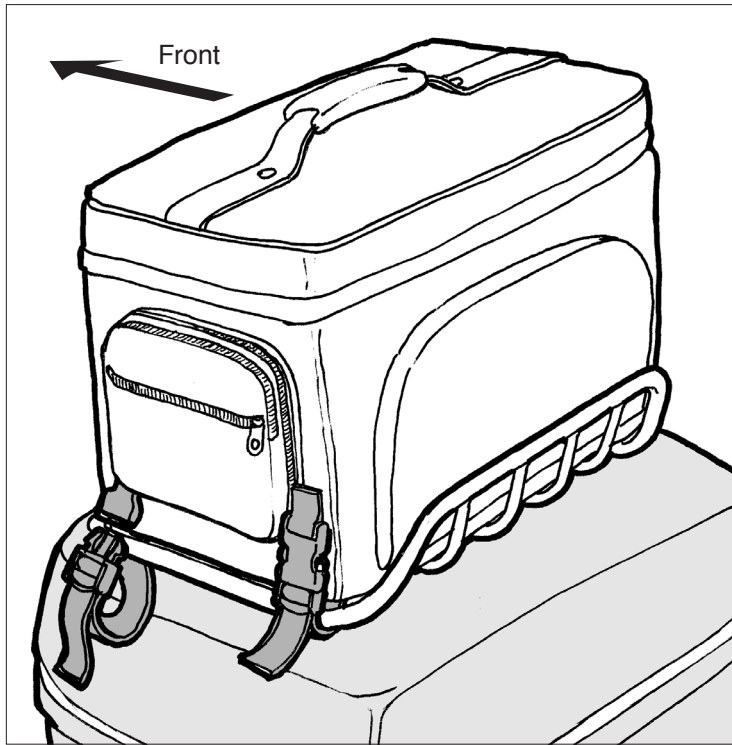

Installation of rain cover

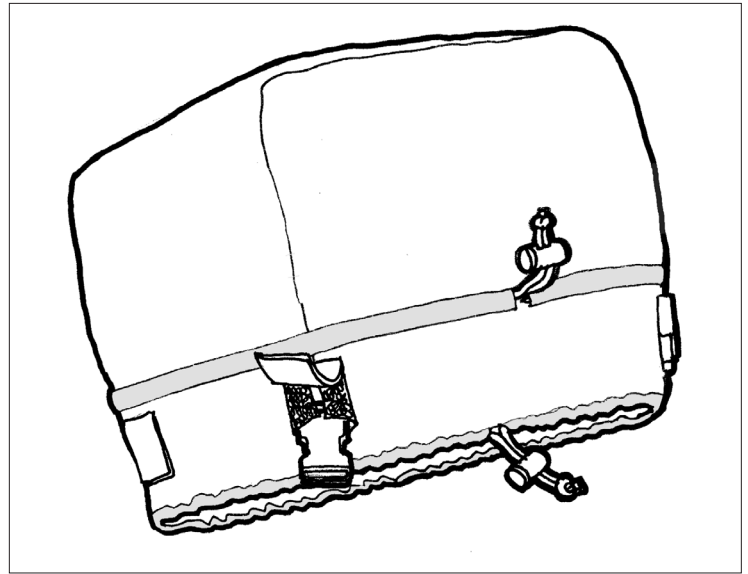

With bag sitting on a luggage rack or top box rails, pass male buckle straps under the rails. Snap male buckles into the female buckles at the base of the bag. Cinch down to firmly fix the bag to the rail of the luggage rack or top box rails.

A rain cover is provided for additional protection in adverse weather conditions. Pull rain cover over bag and cinch down using the cinch cords. The hold-down buckles need to protrude through the Velcro® flap ports in the cover. Re-attach the hold-down straps and cinch bag down after installation of rain cover.

Warning:

Read the installation instructions and make yourself familiar with the process of installing the Nelson-Rigg® product(s) on your bike. It is your responsibility to mount the product correctly and securely as outlined in these instructions. Nelson-Rigg® products are intended for use at USA street legal speeds as posted by the individual States. Nelson-Rigg® luggage must not be overloaded. Max carrying capacity is 10 lbs per bag or the maximum load suggested by the manufacturer of the vehicle, whichever is less.

Failure to adhere to these warnings may result in, but not be limited to: the luggage becoming detached, the product becoming tangled in moving parts of the vehicle, unstable vehicle dynamics, reduction in the ability to control the vehicle. The result(s) of could lead to serious injury.

Always ride safely, adhering to the local highway regulations. Always wear a helmet and protective apparel.

www.nelsonrigg.com

it's not just a bike®

NELSON-RIGG